



Designation: D1336 – 07 (Reapproved 2019)

Standard Test Method for Distortion of Yarn in Woven Fabrics¹

This standard is issued under the fixed designation D1336; the number immediately following the designation indicates the year of original adoption or, in the case of revision, the year of last revision. A number in parentheses indicates the year of last reapproval. A superscript epsilon (ϵ) indicates an editorial change since the last revision or reapproval.

1. Scope

1.1 This test method covers the measurement of yarn distortion of one set of yarns over the other in woven cloth following the application of surface friction. This test method especially is applicable to open-weave fabrics, such as nettings, marquisettes, gauzes, chiffons, and heavier fabrics made from slippery surface yarns.

NOTE 1—For the determination of yarn slippage in woven fabrics, refer to Test Method [D434](#).

1.2 The values stated in SI units are to be regarded as the standard. The inch-pound units given in parentheses are provided for information only.

1.3 *This standard does not purport to address all of the safety concerns, if any, associated with its use. It is the responsibility of the user of this standard to establish appropriate safety, health, and environmental practices and determine the applicability of regulatory limitations prior to use.*

1.4 *This international standard was developed in accordance with internationally recognized principles on standardization established in the Decision on Principles for the Development of International Standards, Guides and Recommendations issued by the World Trade Organization Technical Barriers to Trade (TBT) Committee.*

2. Referenced Documents

2.1 *ASTM Standards:*²

[D123 Terminology Relating to Textiles](#)

[D434 Test Method for Resistance to Slippage of Yarns in Woven Fabrics Using a Standard Seam \(Withdrawn 2003\)](#)³

[D1776 Practice for Conditioning and Testing Textiles](#)

¹ This test method is under the jurisdiction of ASTM Committee [D13](#) on Textiles and is the direct responsibility of Subcommittee [D13.59](#) on Fabric Test Methods, General.

Current edition approved July 1, 2019. Published July 2019. Originally approved in 1954. Last previous edition approved in 2015 as [D1337 – 07\(2015\)](#). DOI: 10.1520/D1336-07R19.

² For referenced ASTM standards, visit the ASTM website, www.astm.org, or contact ASTM Customer Service at service@astm.org. For *Annual Book of ASTM Standards* volume information, refer to the standard's Document Summary page on the ASTM website.

³ The last approved version of this historical standard is referenced on www.astm.org.

[D4850 Terminology Relating to Fabrics and Fabric Test Methods](#)

2.2 *Federal Standard:*

[Federal Test Method Standard 191–Method 5410 Slippage Resistance of Yarns in Cloth, Yarn Distortion Method](#)⁴

3. Terminology

3.1 For all terminology relating to [D13.59](#), Fabric Test Methods, General, refer to Terminology [D4850](#).

3.1.1 The following terms are relevant to this standard: yarn distortion.

3.2 For all other terminology related to textiles, refer to Terminology [D123](#).

4. Summary of Test Method

4.1 A specimen is subjected to a specified shearing force acting in the plane of the fabric. The degree to which the force causes yarns to shift distorting the original symmetry of the weave is taken as a measure of ease of yarn distortion in the fabric. The degree of distortion is reported in terms of the widest opening, measured in hundredths of an inch.

5. Significance and Use

5.1 This test method is considered satisfactory for acceptance testing of commercial shipments because current estimates of between-laboratory precision are acceptable and the method has been used extensively in the trade for acceptance testing.

5.2 In cases of dispute, the statistical bias, if any, between the laboratory of the purchaser and the laboratory of the seller should be determined, with each comparison being based on testing randomized specimens from one sample of fabric.

5.3 This test method is used as an indication of the propensity of yarns to shift or distort in a fabric. Such distortions are objectionable due to the resulting changes in appearance. These appearance changes are sometimes referred to as “finger marks” or “shift marks.”

⁴ Available from General Services Administrations, Specification and Consumer Information and Distribution Section (WFSIS), Washington, Navy Yard, Building 197, Washington, DC 20407.

5.4 It is recommended that fabrics be tested in their original condition and also after laundering or drycleaning, or both, depending upon the intended use of the material.

6. Apparatus

6.1 *Fabric Shift Tester*⁵, as shown in Fig. 1, including:

6.1.1 *Cylindrical Rubber Friction Drums*, consisting of a pair of rubber drums mounted one above the other on the tester in such a way that the specimen may be inserted between their two circular contacting surfaces. Each drum shall be 19 mm (0.75 in.) in diameter and have a Shore Durometer hardness of 55 to 60 (A scale). The lower drum shall be 51 mm (2 in.) in length, fastened to the platform of the apparatus. Facilities shall be provided for rotation of the drums in the mounting frame between tests. The upper drum shall be 25 mm (1 in.) in length, have the same provisions for rotation as the lower one, and shall be so mounted that a total force of 4.5 to 18 N (1 to 4 lbf) can be exerted upon the specimen by means of a lever arm and movable weight.

NOTE 2—The term “weight” is used temporarily in this test method

⁵ The United States Testing Company, Inc., 1415 Park Ave., Hoboken, NJ 07030. The apparatus is described in Federal Test Method Standard 191-Method 5410.

because of established trade usage. The word weight is used to mean both “force” and “mass,” and care must be taken to determine which is meant in each case (SI unit for force = newton and for mass = kilogram).

6.1.2 *Mounting Frame or Bracket*, designed to hold the specimen under uniform tension. The frame shall consist of a rectangle whose inside dimensions are 102 by 153 mm (4 by 6 in.). The 153-mm (4-in.) sides shall be rectangular screw clamps 10 mm (0.375 in.) wide, with the gripping surfaces suitably grooved, taped, or otherwise designed or modified to minimize slipping of the specimen in the clamps during the test. The frame, when placed in the test position on the rails, shall be free to slide as a carriage in a plane perpendicular to the plane of the areas of the friction drums.

6.1.3 *Hand-Crank Arrangement*, for 25 mm (1 in.) reciprocating motion of the carriage. This device, or reciprocating arm, shall have a cam attachment that lifts the upper drum in the return motion.

6.1.4 *Rails*, two sets, fixed and spaced on the platform of the tester, for supporting the carriage.

6.2 *Jig*, for mounting the specimen in the frame under tension of 22.2 ± 0.22 N (5 ± 0.05 lbf). A suitable device consists of a clamp and weight (Fig. 1) having a total mass of 2.3 kg (5 lb).

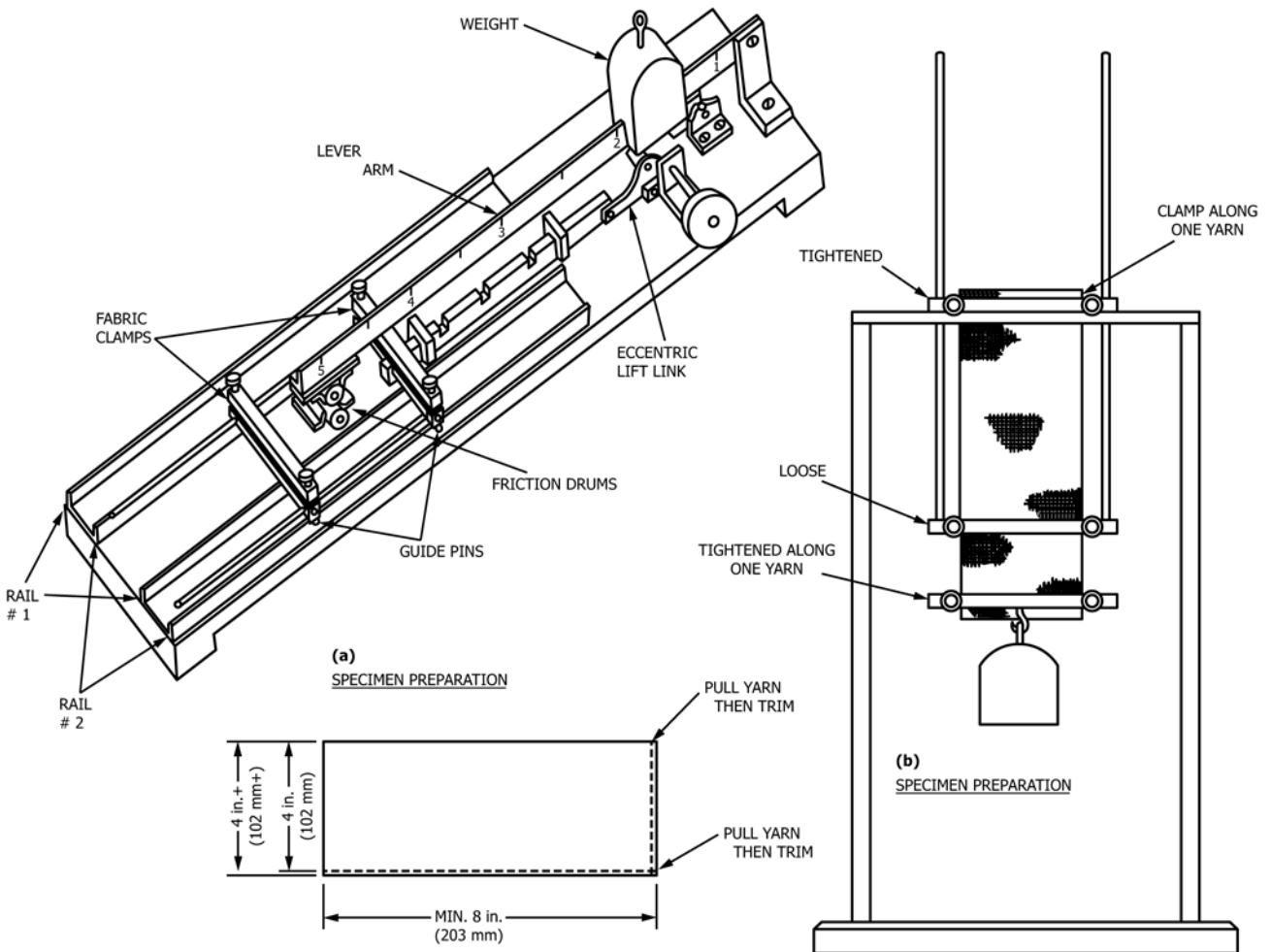

FIG. 1 Fabric Shift Tester